

## COMPACT 14

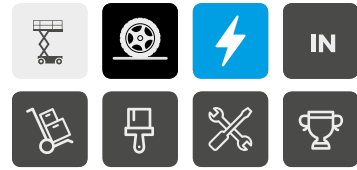

### EXCEPTIONAL PRODUCTIVITY

- > Working height up to 13.85 m
- > Driveable at full height
- > Load capacity: 350 kg
- > Robust, reliable, easy to maintain
- > Extended platform
- > Long working cycles

### OPTIMUM COMPACTNESS

- > 1.2 m width
- > Folding guardrails



# COMPACT 14

## ELECTRIC SCISSOR LIFTS

### TECHNICAL DATA

### COMPACT 14

Working height	13.85 m
Platform height	11.85 m
Maximum drive height	11.85 m
Lift capacity - inside	350 kg (3 pers.)
Lift capacity on the extension	150 kg
<b>A</b> Platform length - outside	2.31 m
Platform length - extended	3.23 m
Length - extension	0.92 m
Platform width - outside	1.2 m
<b>D</b> Storage height	2.08 m
<b>C</b> Height - stowed	2.5 m
<b>B</b> Overall width	1.2 m
<b>E</b> Length	2.49 m
<b>F</b> Wheelbase	1.86 m
<b>G</b> Ground clearance - center	13 cm
Ground clearance - deployed potholes	2.3 cm
Drive speed	0.9 - 2.7 km/h
Gradeability	23 %
Tilt	2° / 3°
Turning radius - outside	2.5 m
Non-marking tyres	15 x 5
Batteries	24 V - 340 Ah (C20)
Hydraulic system capacity	25 l
Weight	3 175 kg

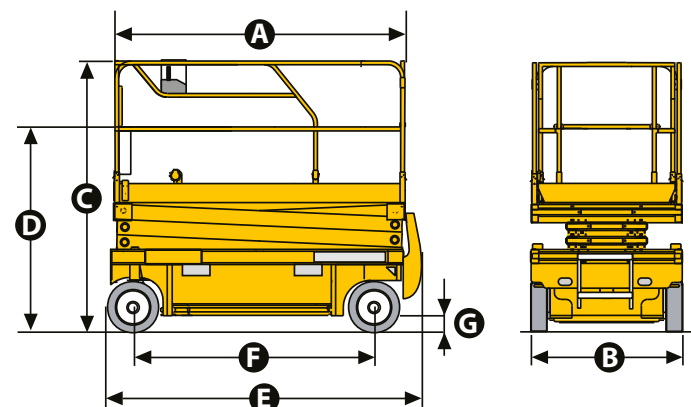

### STANDARD EQUIPMENT

- > 24 V DC motor
- > Battery charger with automatic stop
- > Battery charge indicator
- > Integrated forklift pockets
- > Pothole guards
- > Proportional lift and drive
- > 2 front steering & driving wheels
- > Folding handrails
- > Solid non-marking tyres
- > Brake release
- > Swing out component tray
- > Load Management System in the platform
- > Tilt controller
- > Hourmeter
- > Horn
- > Removable control box in platform
- > Manual platform lowering valve
- > Towing hooks

### OPTIONS AND ACCESSORIES

- > Power to platform
- > Swing door entry gate
- > Biodegradable hydraulic oil
- > Centralised battery filling
- > Pipe cradle
- > Flashing light
- > Working light

