

## HT23 RTJ PRO



### OUTSTANDING PERFORMANCE & PRODUCTIVITY

- > Very good working envelope
- > Basket load capacity 230 kg
- > Dual load 230-450 kg (option)

### RELIABLE SAFETY & COMFORT

- > Haulotte Activ' Shield Bar 2.0
- > Haulotte Activ' Lighting System for safe loading/unloading in conditions of low visibility
- > Quick, proportional and simultaneous movements
- > Rugged boom design

### MAXIMIZED TOTAL COST OF OWNERSHIP

- > Haulotte Activ'Screen diagnostic display for onboard fault & service alerts
- > Haulotte Stop Emission System automatically turns the engine off & on
- > Easy access to all components
- > Exclusive modular platform, easy and quick to repair

AVAILABLE  
Q4 2018

AVAILABLE  
Q4 2018

# HT23 RTJ PRO

ROUGH TERRAIN  
TELESCOPIC BOOMS

## TECHNICAL DATA

### HT23 RTJ PRO

Working height	22.5 m
Platform height	20.5 m
Horizontal outreach	18.3 m
Below ground reach	4 m
Lift capacity	230 kg - 2 pers. (option : 450 kg - 3 pers.)
<b>F</b> x <b>G</b> Platform size	2.44 x 0.91 m
<b>A</b> Length - stowed	10.4 m
<b>H</b> Length - transport	7.8 m
<b>B</b> Overall width	2.47 m
<b>C</b> Height - stowed	2.7 m
Height - transport	3.3 m
Vertical jib rotation	133° (+68/-65)
Platform rotation	180° (+90/-90)
Boom rotation angle	90° (+75/-15)
Turntable rotation	360 ° continuous
Tailswing	109 cm
<b>D</b> Wheelbase	2.5 m
<b>E</b> Ground clearance	34 cm
Tilt	5°
Drive speed	0.5 - 6.5 km/h
Gradeability	40 %
Turning radius - outside	3,4 m
Tyres - foam-filled	385/65 - 22.5
Engine	Kubota, 36.5kW (49.6hp), Stage 3A
Weight	13 400 kg

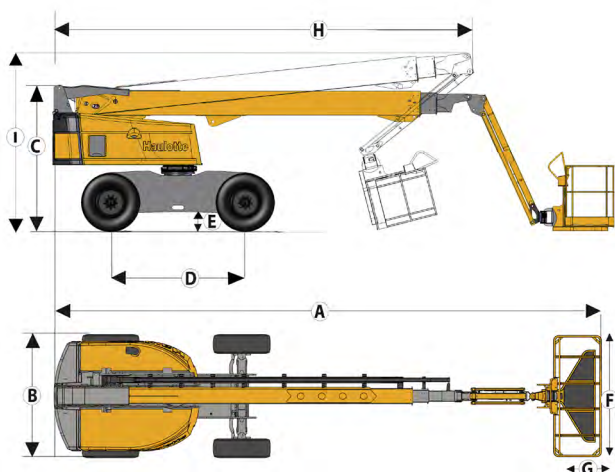

\*Available Q4 2018

## STANDARD EQUIPMENT

- > Haulotte Activ'Lighting System
- > Haulotte Stop Emission System
- > Haulotte Activ'Shield Bar 2.0
- > Haulotte Activ'Screen onboard colored monitor screen and diagnostic system
- > Universal telematics plug
- > 4 wheel drive / 2 (O) or 4 (PRO) wheel steer
- > Front oscillating axle increases stability on uneven terrain
- > Proportional controls enhance comfort and safety
- > 4 simultaneous movements for maximum productivity
- > Automatic wheel lock differential increases rough terrain capacity
- > Upper control box protection cover and tool tray in ultra-rugged composite
- > 230 kg unrestricted load capacity working envelope
- > Large modular platform 2.44 x 0.91 m, Drop entry gate
- > Platform limitation +/- 10°
- > 110 / 230 V power to platform
- > Swing out engine tray for ease of maintenance
- > Sound and light alarm for tilt and load
- > Maximum wind speed 45 km/h
- > Rotating beacon
- > Driving alarm
- > Hour meter
- > Emergency descent electric pump system
- > 12 V battery
- > Engine pre-heater with light indicator
- > Low fuel level indicator (upper control box)

## OPTIONS AND ACCESSORIES

- > Dual load capacity 230 - 450 kg (2 / 3 persons)
- > Narrow modular platform: 1,83m x 0,8 m
- > 110 / 220 V Power to platform
- > Air line to platform
- > Lateral swing door entry gate
- > 3.5 kW, 6,5 kW, 12 kW hydraulic generator
- > Biodegradable hydraulic oil
- > 60 km wind speed
- > Warm weather package
- > Cold weather package / Arctic Kit
- > Glazier kit
- > Pipe rack kit
- > Work light package

